

# Datasheet E018

Robust explosion proof indicator

**FLUIDWELL**  
Accurate Liquid Management

Reliable

*Count on us.*

## Flow Monitor / Totalizer

with linearization, high / low alarms, analog and pulse signal outputs and HART Communication



**HART**  
COMMUNICATION PROTOCOL

### Advantages

- ✔ Save time and gain flexibility with the easy-to-operate through glass keypad: no need to remove the front cover or to arrange a work permit.
- ✔ Your crew is in control with our highly praised "know one, know them all" configuration structure, saving time, cost and aggravation.
- ✔ Easy installation with the spacious chamber and plug and play connectors.
- ✔ Cost saving with an easy to install, 1" NPT thread for flow meter mounting.
- ✔ Durable high grade stainless steel 316L Ex d enclosure for extremely salty atmospheres (offshore).
- ✔ Key information at a glance as the display shows flow rate, total, measuring units and a flow rate indicating speedometer.

### Features

- ✔ Explosion proof according [ATEX](#), [IECEx](#) and [CSA C-US](#).
- ✔ 7 digit flow rate / total and 11 digit accumulated total.
- ✔ 16 point linearization of the flow curve - with interpolation.
- ✔ High and low flow rate alarm monitoring.
- ✔ Clear flashing LED backlight in case of an alarm.
- ✔ Power options: Loop powered, battery and 9 - 27V DC.
- ✔ Sensor supply 8.2 / 12 / 24V DC.

### Outputs

- ✔ Integrated HART 7 communication protocol.
- ✔ Isolated, loop powered 4 - 20mA output according to linearized flow rate.
- ✔ Four configurable digital outputs for high and low flow rate alarms or scaled pulse retransmission of the linearized accumulated total.

### Inputs

- ✔ Ability to process all types of volumetric or mass flow meter signals: Reed-switch, NAMUR, NPN/PNP pulse, Sine wave (coil), Active pulse signals.

### Applications

- ✔ Flow measurement in an explosion proof application with mechanical flow meters, where re-transmission of the totalizer, monitoring of the flow rate and HART communication is required.
- ✔ The E018 offers you a flow rate monitor / totalizer designed to be used in rough and tough applications, beyond being just explosion proof. Its sturdy design and ease of use are unequalled by any other explosion proof indicator in the market! The E-Series is always your first and safest choice in explosion proof applications.
- ✔ For intrinsically safe applications we offer our field mount [F-Series](#) indicators.

## General information

### Introduction

The Eo18 is one of the top models in our range of explosion proof flow computers. The E-series distinguishes itself by its quality and functionality driven European design and manufacturing. It is more than fulfilling the rules for explosion proof design, it is about safety during the daily operation. Often, the environment is much tougher than the explosion proof requirements demand. Thus dangerous conditions may be experienced due to a broken enclosure or a poorly made flame path. Ruggedness and reliability is where Fluidwell stands for and it is now available in a comprehensive well designed and purpose driven explosion proof flow monitor / totalizer.

### Display

The unique LCD display provides multiple flow data at a glance. The main information is displayed with 7 digits (12mm, 0.47") to show total or flow rate and 11 digits (7mm, 0.28"), which can be set to show flow rate and accumulated total. On-screen engineering units are easily configured from a comprehensive selection, while different units for flow rate and total can be displayed simultaneously. The speedometer offers a quick impression of the actual flow rate. The Eo18 is provided with a bi-color backlight, which can be turned on to flashing red to indicate a flow rate alarm condition. When battery powered the backlight is only operational after a keypad touch, to extend battery lifetime.

### Configuration

The E-Series uses the highly appreciated configuration structure of our F-, D- and N-Series product line. Each setting is clearly indicated with an alphanumeric description, which avoids confusing abbreviations. Once familiar with one E-series product, you will be able to program all models in all series without a manual. For example: an (intrinsically safe) Fo18 operates identical to an explosion proof Eo18 and has the same three buttons! In other words: know one, know them all. Operation is done via the optical, easy-to-operate, through glass keypad without having to remove the front cover. If required, these optical keys can be disabled. For easy handheld configuration there are three mechanical push buttons on the bottom side of the display collar. All settings can be password protected.

### Flow meter input

The Eo18 accepts most input signals for volume flow or mass flow meters. The input signal type can be selected in the configuration menu without having to adjust any sensitive mechanical dip-switches or jumpers. In addition to the average K-Factor, 16 linearization points can be entered with their frequencies or values. The unit will interpolate between these points greatly enhancing accuracy in any flow range.

### High grade Stainless Steel 316L enclosure



### Easy-to-operate through glass keypad



### Robust side entry thread (T1)

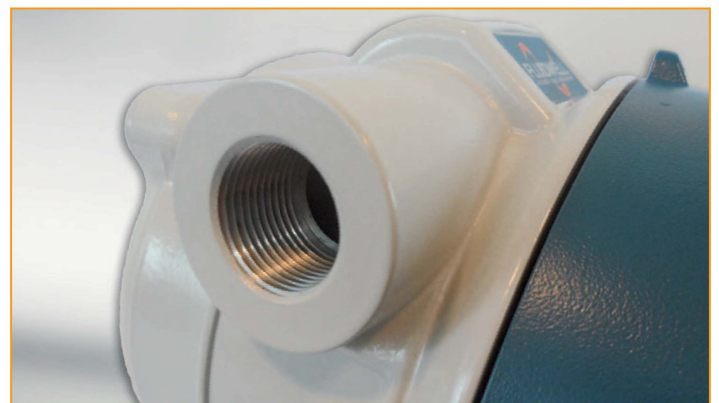

### Robust bottom entry thread (T2)



## Analog output

The linearized flow rate is transmitted with the galvanically isolated 4 - 20mA output signal. The Eo18 can even be loop powered via the isolated loop-current.

## Pulse / Alarm outputs

Four digital outputs are available, which can be set as an alarm output to transmit the flow rate alarm or as a scaled pulse output. The alarm output can be set to switch for a low, high or all alarms! Scaled pulse output is according the linearized accumulated total. The pulse length is user defined from 1msec. up to 10 seconds. The output can be a passive NPN signal or a mechanical relay output.

## HART Communication

All process data and every single menu setting can easily be read and modified via the HART communication link with a [free downloadable device-specific DD](#). This guarantees that they will operate hassle free with other registered DD enabled host systems. Fluidwell lifts the user-friendly configuration to the next level!

## Power requirements

Several power inputs are possible to power the Eo18 and sensor. As standard the Eo18 can be loop powered via the isolated, two-wire, analog output. The battery powered version with a long life lithium battery and the basic 9 - 27V DC can power the Eo18 including the backlight, but don't offer a real sensor supply. A real sensor supply of 8.2, 12 or 24V is optional available with type PD.

## Hazardous areas

The E-Series has been certified according ATEX, IECEx and CSA c-us with an ambient temperature of -40°C to +70°C (-40°F to +158°F).

The application range of the enclosure is very wide:

☑ The **ATEX markings** are:

Gas:  $\text{Ex II 2 G Ex d IIC T6 Gb}$

Dust:  $\text{Ex II 2 D Ex tb IIIC T85°C Db}$

☑ The **IECEX markings** are:

Gas:  $\text{Ex d IIC T6 Gb}$

Dust:  $\text{Ex tb IIIC T85°C Db}$

☑ The **CSA c-us markings** are:

XP (Explosion-proof): Class I, Division 1, Grps A, B, C, D.

DIP (Dust-Ignition-proof): Class II/III, Division 1, Groups E, F and G. Class I, Zone 1, AEx d IIC T6 Gb, Zone 21, AEx tb IIIC T85°C Db.

## Enclosures

Two fundamental versions of our IP66/IP67, NEMA 4X/7/8/9 explosion proof enclosures are available: a solid die cast aluminum or a heavy duty stainless steel 316L enclosure resistant to extremely salty atmospheres (offshore). The aluminum enclosure has an industrial two component coating and is better suitable for outdoor and chemical plant applications than powder coated alternatives.

A major advantage for the installation engineer is the spacious mid-chamber for the cable entry in combination with the plug-and-play connectors. Various NPT and metric connections threads are available. Especially for use on top of Turbine meters a 1" NPT connection is available for straight flow meter mounting

(see page 4 for the various threads sizes available).

## Overview application Eo18

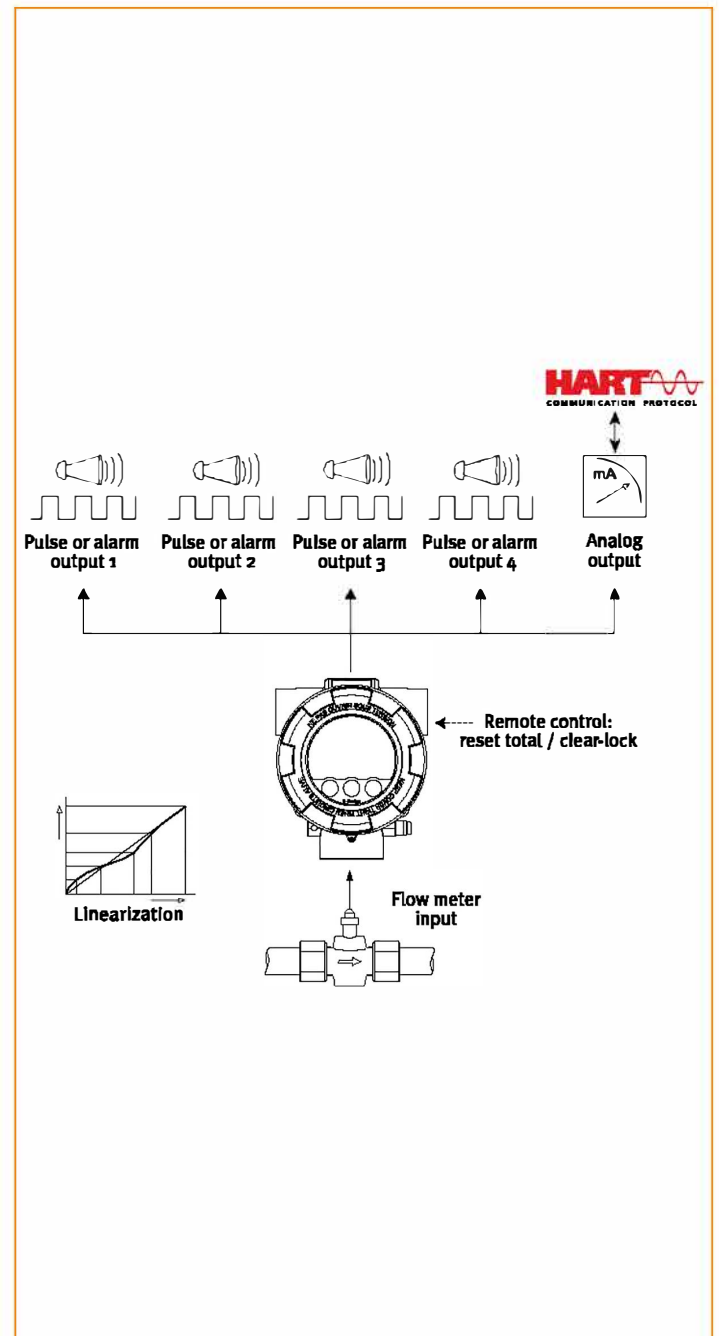

## Dimensions enclosures

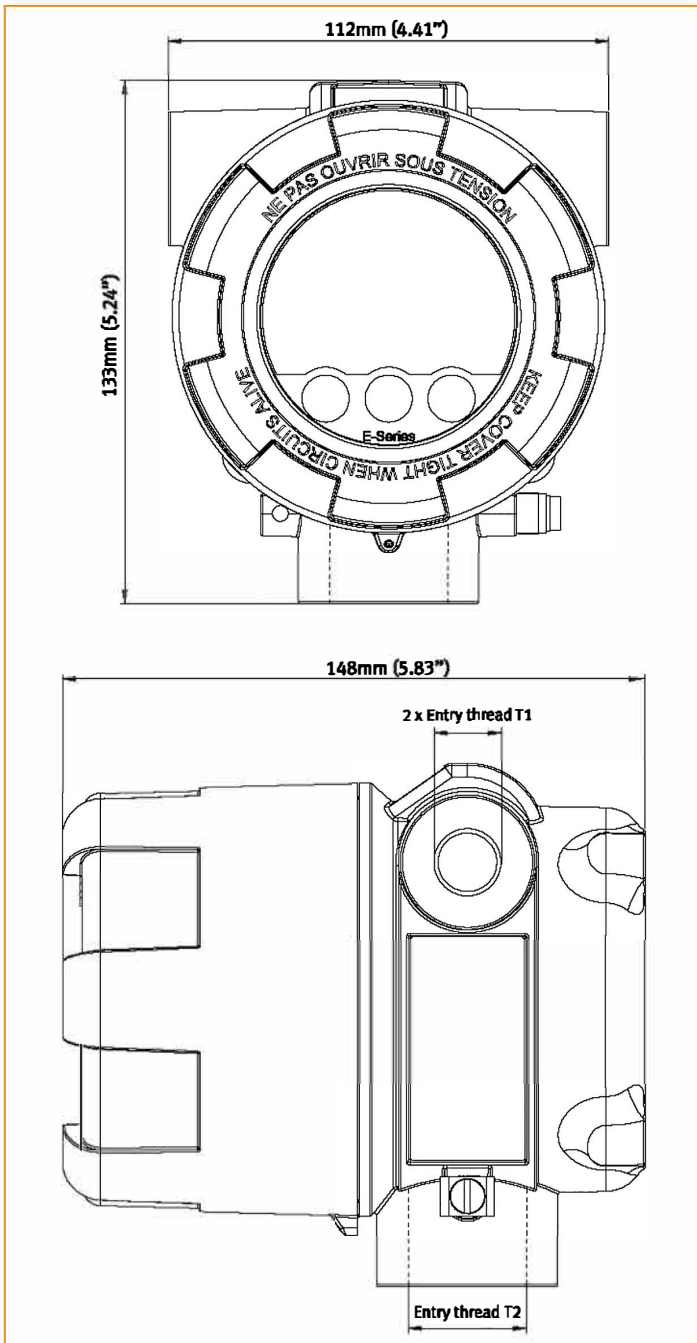

### Enclosure types

Type HA_	Die-cast aluminum Ex d enclosure.
Weight	1300 gr.
Type HS_	Stainless steel 316L Ex d enclosure.
Weight	3600 gr.

### Enclosure drillings

Type H_A	Entry threads: 2 x 3/4" NPT / 1 x 1" NPT
Type H_B	Entry threads: 3 x 3/4" NPT
Type H_C	Entry threads: 2 x 1/2" NPT / 1 x 1" NPT
Type H_D	Entry threads: 2 x 1/2" NPT / 1 x 3/4" NPT
Type H_G	Entry threads: 2 x M20 / 1 x M25
Type H_H	Entry threads: 3 x M25

## Terminal connections

### Main Electronics Module

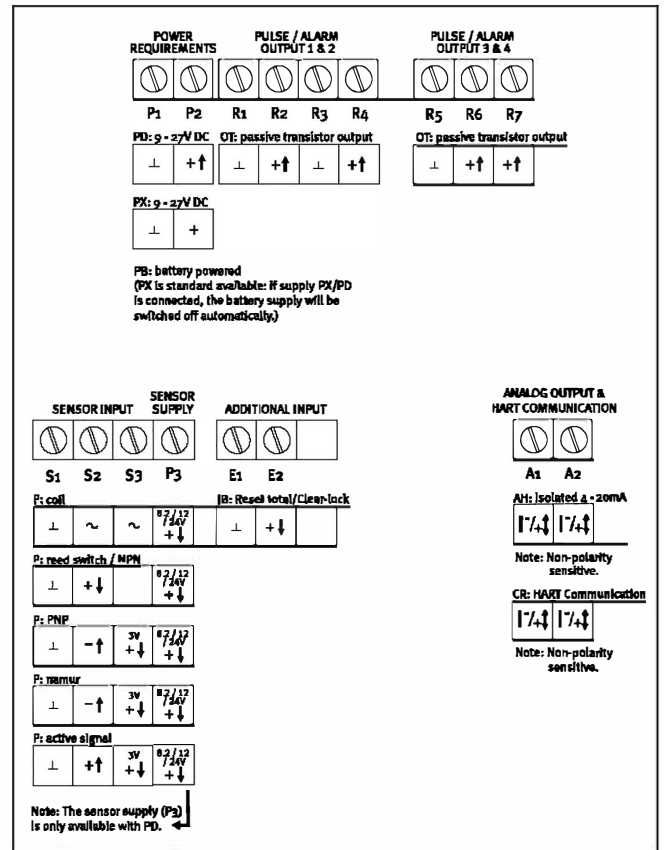

### Supply Module

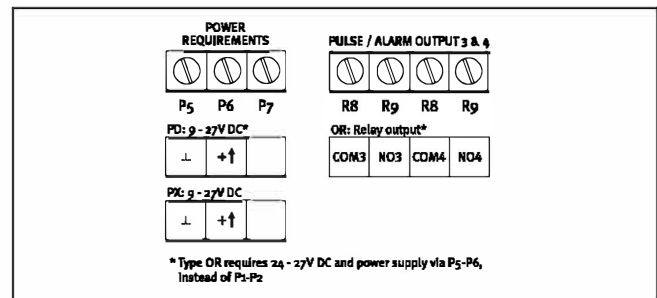

## Display example - 1:1

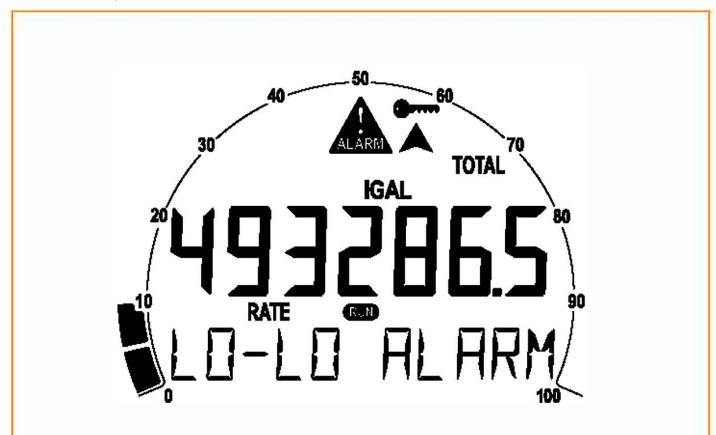

Typical wiring diagram Eo18-P-AH-CR-IB-OR-PD

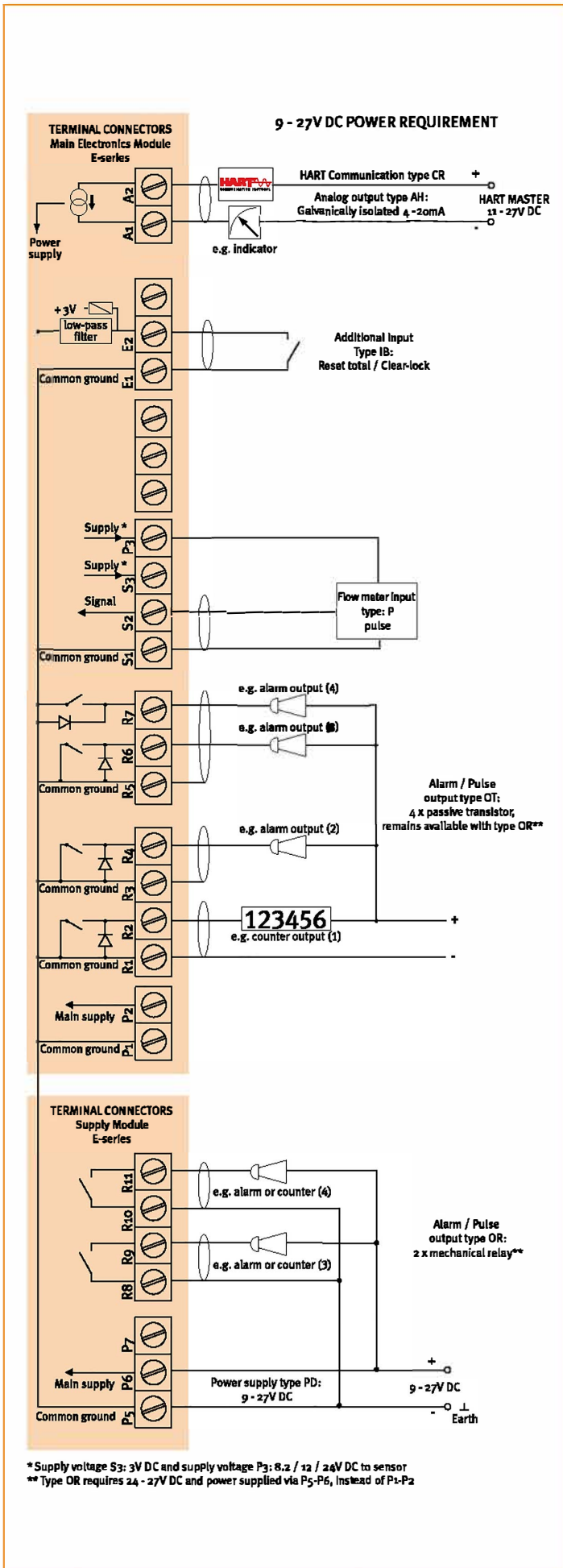

Typical wiring diagram Eo18-P-AH-CR-IB-OT-PX

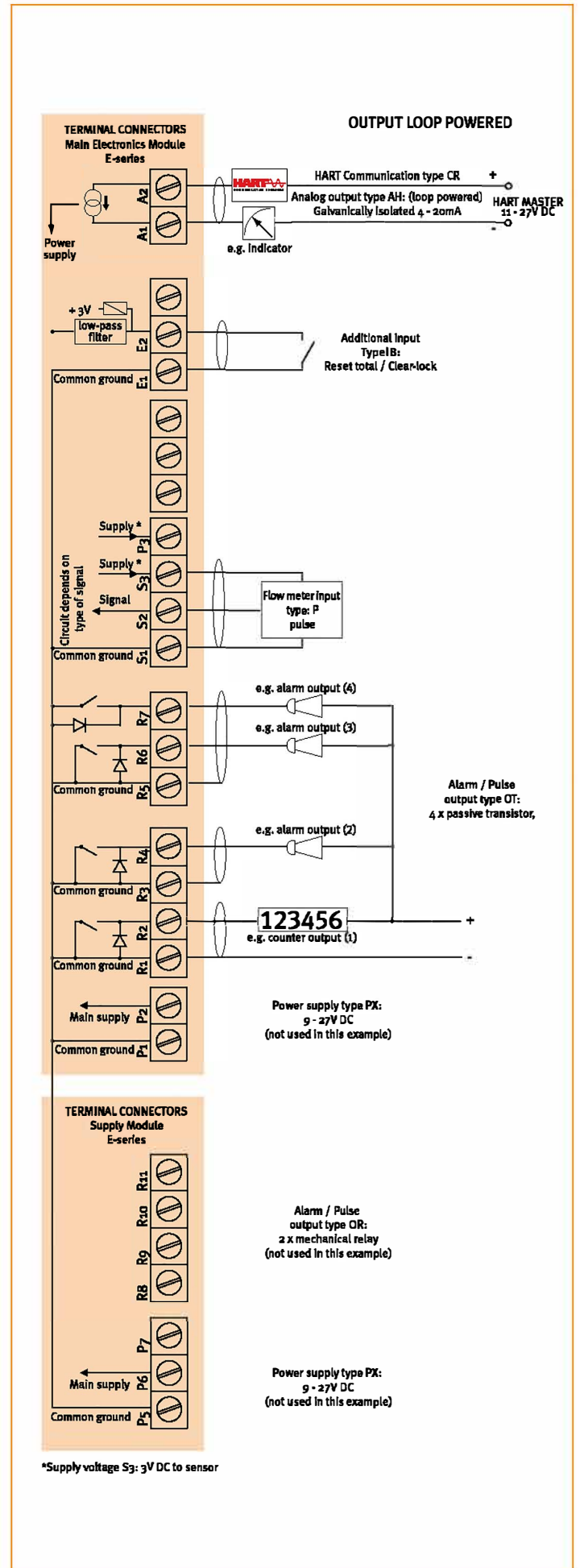

## Technical specification

### General

Display	
Type	High intensity transfective numeric and alpha-numeric LCD, UV-resistant, with bi-color backlight. Red (flashing) backlight during alarm conditions. Intensity can be adjusted via the keypad.
Note	When battery powered, the backlight is only operational after a keypad touch, to extend battery lifetime.
Dimensions	Ø 65 x 45mm (2.56" x 1.77").
Digits	Seven 12mm (0.47") and eleven 7mm (0.28") digits. Various symbols and measuring units.
Refresh rate	User definable: 8 times/sec. - 30 secs.
Speedometer	To indicate the actual flow rate the bargraph runs from 0 to 100% in 20 blocks, each block is 5%.

### Operating temperature

Ambient	-40°C to +70°C (-40°F to +158°F).
---------	-----------------------------------

### Power requirements

Type PB	Long life Lithium battery - life-time depends upon settings and configuration - up to approx. 3 years.
Note PB	The battery can power the backlight for a short time after a keypad touch but cannot power the relay output (OR) or the real sensor supply (Terminal P <sub>3</sub> ).
Type PD	9 - 27V DC. Consumption max. 4.5W.
Type PX	9 - 27V DC. Consumption max. 4.5W.
Type AH	Loop powered, analog output. 11 - 27V DC, Min. 3.5mA. Consumption max. 675mW (25mA @ 27VDC).
Note AH	The loop powered analog output cannot power the backlight, mechanical relay output (OR) or the real sensor supply (Terminal P <sub>3</sub> ).

### Sensor excitation

Type AH/PB/PX	Terminal S <sub>3</sub> : 3V DC for pulse signals and 1.2V DC for coil pick-up, I <sub>out</sub> max. 100µA.
Note	This is not a real sensor supply. Only suitable for sensors with a very low power consumption like coils (sine wave) and reed-switches.
Type PD	Terminal P <sub>3</sub> : 8.2 / 12 / 24V DC 8.2V DC, I <sub>out</sub> max. 20mA. 12V DC, I <sub>out</sub> max. 30mA. 24V DC, I <sub>out</sub> max. 75mA (this voltage varies depending on the input supply voltage)

### Terminal connections

Type	Removable plug-in terminal strip. Wire max. 1.5mm <sup>2</sup> and 2.5mm <sup>2</sup> .
------	--

### Data protection



Type	EEPROM backup of all settings. Backup of running totals every minute. Data retention at least 10 years.
Pass-code	Configuration settings can be <u>pass-code</u> protected.

### Directives & Standards

EMC	Directive 2004/108/EC, FCC 47 CFR part 15.
Low voltage	Directive 2006/95/EC.
ATEX / IECEx	Directive 94/9/EC, IEC 60079-0, IEC 60079-1, IEC 60079-31.
CSA	CSA 22.2 No. 25, No. 30.
IP & NEMA	EN 60529 & NEMA 250.

### Hazardous area

#### Explosion proof

Ambient Ta	-40°C to +70°C (-40°F to +158°F).
ATEX certification	Gas:  II 2 G Ex d IIC T6 Gb. Dust:  II 2 D Ex tb IIIC T85°C Db.
IECEX certification	Gas: Ex d IIC T6 Gb. Dust: Ex tb IIIC T85°C Db.
CSA c-us certification	Class I, Div. 1, Grps A, B, C, D. Class II/III, Div. 1, Grps E, F, & G. Class I, Zone 1, AEx d IIC T6 Gb, Zone 21, AEx tb IIIC T85°C Db.

### Enclosure

General	
Window	Glass window.
Sealing	Silicone.
Control keys	Three infra-red keys with operation through the glass front window.
Rating	IP66, IP67 / NEMA 4X / NEMA 7 / NEMA 8 / NEMA 9.
Dimensions	112 x 133 x 148mm (4.41" x 5.24" x 5.83") - W x H x D.

### Enclosure types

Type HA_	Die-cast aluminum Ex d enclosure.
Weight	1300 gr. (3.48 lbs).
Type HS_	Stainless steel 316L Ex d enclosure.
Weight	3600 gr. (9.65 lbs).

### Enclosure drillings

Type H_A	Entry threads: 2 x 3/4"NPT / 1 x 1"NPT
Type H_B	Entry threads: 3 x 3/4"NPT
Type H_C	Entry threads: 2 x 1/2"NPT / 1 x 1"NPT
Type H_D	Entry threads: 2 x 1/2"NPT / 1 x 3/4"NPT
Type H_G	Entry threads: 2 x M20 / 1 x M25
Type H_H	Entry threads: 3 x M25

## Signal input

### Flow meter sensor

Type P	Coil / sine wave (COIL-HI: 20mVpp or COIL-LO: 80mVpp sensitivity selectable), NPN, PNP, reedswitch, Namur, active pulse signals 8 or 24V DC.
Frequency	Minimum 0Hz - maximum 7kHz for total and flow rate. Maximum frequency depends on signal type and internal low-pass filter. E.g. reed switch with low-pass filter: max. frequency 120Hz.
K-Factor	0.000010 - 9,999,999 with variable decimal position.
Low-pass filter	Available for all pulse signals.
Option ZF	coil sensitivity 10mVpp.
Option ZG	coil sensitivity 5mVpp.

### Additional input signal

Function	Terminal input to reset total remotely or to lock the "clear total" button.
Type IB	Internally pulled-up switch contact - NPN.
Duration	Minimum pulse duration 100msec.

## Signal outputs

### Digital outputs

Function	<ul style="list-style-type: none"> <li>Pulse output: Transmitting accumulated total.</li> <li>Alarm output: Low, high or both alarms.</li> </ul>
Note	All four outputs are user defined: pulse output, low-low, low, high, high-high or all alarm outputs.
Frequency	Max. 500Hz. Pulse length user definable between 1msec up to 10 seconds.
Type OR	Two Isolated electro-mechanical relay outputs (NO). Maximum resistive load: 2A @ 250V AC / 30V DC. Maximum inductive load: 0,5A (pilot duty applications). Type OT remains also available.
Restrictions OR	Requires 24 - 27V DC and supplied via P5 - P6. Frequency max. 5Hz.
Type OT	Four passive transistor outputs (NPN) - not isolated. 300mA - 50V @ 25°C.

### Analog output

Function	Transmitting linearized flow rate.
Type AH	Galvanically isolated, loop powered 4 - 20mA output
Accuracy	12 bit. Error 0.05% of full scale at 25°C (77°F), 40ppm/°C temperature drift. Analog output signal can be scaled to any desired range.

### HART Communication

Function	Reading display information, reading / writing all configuration settings.
Type CR	HART Communication protocol, Revision 7.0.
Liftoff voltage	11V.
Loop resistance	250 Ohm.
Addressing	Selectable 0 - 63 addresses.

## Operational

### Operator functions

Displayed functions	<ul style="list-style-type: none"> <li>Linearized flow rate and / or total.</li> <li>Linearized total and accumulated total.</li> <li>Low flow rate alarm value.</li> <li>High flow rate alarm value.</li> <li>Indicating speedometer for linearized flow rate.</li> <li>Total can be reset to zero by pressing the CLEAR-key twice (password protected).</li> <li>Alarm values can be set (or only displayed).</li> </ul>
---------------------	--

### Total

Digits	7 digits.
Units	L, m <sup>3</sup> , US gal, igan, cf, Oil bbl, kg, ton, US ton, lb or none.
Decimals	0 - 1 - 2 or 3.
Note	Total can be reset to zero.

### Accumulated total

Digits	11 digits.
Units / decimals	According to selection for total.
Note	Can not be reset to zero.

### Flow rate

Digits	7 digits.
Units	mL, L, m <sup>3</sup> , mg, g, kg, ton, US ton, US gal, igan, Oil bbl, lb, cf, rev, none, scf, nm <sup>3</sup> , nL or p.
Decimals	0 - 1 - 2 or 3.
Time units	/sec - /min - /hr - /day.

### Alarm values

Digits	7 digits.
Units	According to selection for flow rate.
Decimals	According to selection for flow rate.
Time units	According to selection for flow rate.
Type of alarm	Configurable low-low, low, high, high-high or all flow rate alarms. Includes alarm delay time.

## Accessories

### E-Series accessories

ABB01-07	Brass nickel plated blind plugs.
ABS01-07	Stainless steel blind plugs.
ARB01-04	Brass nickel plated reducers.
ARS01-04	Stainless steel reducers.
ACE01	USB data logging and configuration cable.
ACE02	Remote configuration cable.
ACE03	Stainless steel wall mounting kit (inc. screws+plugs).
ACE04	Stainless steel pipe mounting kit.
ACE05	2 pins, 30cm (12") cable with Amphenol connector.
ACGo8	MTL5541AS barrier - For hazardous area 4-20mA with HART Communication to safe area, with current sink for safe area connection.

# Datasheet E018

Robust explosion proof indicator



Reliable

Count on us.

## Ordering information (in alphabetical order)

Standard configuration: E018-P-AH-CX-HAA-IB-OT-PX-XD-ZB.

Ordering information: E018	-P	-AH	-C	-H	-IB	-O	-P	-XD	-Z
<b>Flow meter input signal</b>									
<b>P</b> Pulse input: coil, npn, pnp, namur, reed-switch.									
<b>Analog output signal</b>									
<b>AH</b> Galvanically isolated, loop powered 4-20mA output.									
<b>Communication</b>									
<b>CR</b> HART communication.									
<b>CX</b> No communication.									
<b>Enclosure types - IP66,IP67 / NEMA 4X / NEMA 7 / NEMA 8 / NEMA 9.</b>									
<b>HA</b> Die-cast aluminum Ex d enclosure.									
<b>HS</b> Stainless steel 316L Ex d enclosure.									
<b>Enclosure drillings</b>									
<b>H_A</b> Entry threads: 2 x 3/4"NPT / 1 x 1"NPT.									
<b>H_B</b> Entry threads: 3 x 3/4"NPT.									
<b>H_C</b> Entry threads: 2 x 1/2"NPT / 1 x 1"NPT.									
<b>H_D</b> Entry threads: 2 x 1/2"NPT / 1 x 3/4"NPT.									
<b>H_G</b> Entry threads: 2 x M20 / 1 x M25.									
<b>H_H</b> Entry threads: 3 x M25.									
<b>Additional input signal</b>									
<b>IB</b> Remote control input to reset total or to lock the "clear total" button.									
<b>Digital output signals</b>									
<b>OR</b> 2 mechanical relay outputs (OT remains available) - requires 24 - 27V DC.									
<b>OT</b> 4 passive transistor outputs - standard configuration.									
<b>Power requirements</b>									
<b>PB</b> Lithium battery powered.									
<b>PD</b> 9 - 27V DC + sensor supply.									
<b>PX</b> Basic power input 9 - 27V DC (no real sensor supply).									
<b>Hazardous area</b>									
<b>XD</b> Explosion Proof enclosure according to ATEX, IECEx and CSA c-us.									
<b>Other options</b>									
<b>ZB</b> Backlight is included as standard.									
<b>ZF</b> Coil input 10mVpp.									
<b>ZG</b> Coil input 5mVpp.									

The bold marked text contains the standard configuration.



www.cencalinst.com



Important: Specifications are subject to change without notice.  
Copyright: Fluidwell bv - 2015 - E018-DATA-EN-V1540